



River Deben Association

River Deben Association Saltmarsh Research Group

Saltmarsh Research on the River Deben

By Richard Steward and Robin Whittle



Ramsholt looking towards Woodbridge - Mike Page Aerial Photography

Researching the causes of saltmarsh loss

River Deben Association Saltmarsh Research Group

Saltmarsh Research on the River Deben

By Richard Steward and Robin Whittle

Contents	Page
1. Synopsis	1
2. Acknowledgements	2
3. Introduction	2
4. Historic background	3
5. Description	4
6. Results and discussion	10
7. Conclusions	15
8. References	16
Annex A: Loder's Cut Island survey of vegetation (21 June 2014)	17
Annex B: Equipment for measuring the level of mud	21
Annex C: Sea level rise	23
Annex D: Internal erosion of saltmarsh	24
Annex E: 'Coastal Squeeze'	26

1. Synopsis

This paper describes the research work that has been carried out by the River Deben Association Saltmarsh Research Group (RDA SRG) in three different areas of the saltmarsh of the river Deben. The purpose of the work (started in 2014) has been to measure:

- Changes in saltmarsh level
- Changes in mud level in the drainage channels
- The effect of ragworm exclusion plates on mud levels in the drainage channels
- The effect of shore crab exclusion cages on mud levels in the drainage channels
- The erosion rate at the edges of the saltmarsh
- The effect of creating an impermeable sill in two of the channels
- The effect of placing crab exclusion netting along the edge of the saltmarsh.

Special equipment has been developed to measure the mud level in the saltmarsh channels and lagoons. Work is ongoing at the time of this report (December 2020). So far, the results confirm that:

- The saltmarsh is rising at a similar rate to that of Mean High Water Springs (MHWS) sea level rise (about 3.5mm/year).
- In addition to the erosion of the saltmarsh taking place along the river edges of 0.6ha/year measurements show that 0.83ha/year erosion is taking place within the heart of the saltmarsh (increasing the size of channels and lagoons).
- The rate of accretion in an artificially trapped lagoon area of the saltmarsh has resulted in a rise of the mud level of 15mm/year
- New saltmarsh can be created from the use of dredgings.
- Rag worms may help to prevent mud loss in the saltmarsh drainage channels and lagoons.

2. Acknowledgements

The authors would like to thank the following people for their contributions to the survey work: Gillie Whittle, James Skellorn, Jamie Whittle, Hazel and Tristan Whittle, and Cameron Fullerton

3. Introduction

The river Deben saltmarsh began life about 6500 years ago when the rapidly rising sea level of that time entered today's estuary around Felixstowe Ferry, and the fringing freshwater marsh began converting into an expanding saltwater marsh. Over this time, through the deposition of sea borne clay sediments, the saltmarsh surface has risen some 14m, expanded 3km to the sides in the lower reaches and penetrated 18km upstream.

The saltmarsh surface equals and rises with Mean High Water Springs (MHWS) currently about 1.75m (+/-100mm) above Ordnance Datum (OD) and rising about 3.5mm/year since the mid-17th century.

Since the early 17th century over 1500ha of saltmarsh has been embanked to create freshwater grazing marsh and arable land. Today only about 235ha of the original tidal saltmarsh are left. Once embanked, the land elevation is fixed and records the MHWS level of the time allowing the date of embankment to be estimated from the height difference between the external tidal saltmarsh and the embanked freshwater marsh at 3.5mm/yr. (Note: Clay marshes with a regulated water table (usually -0.3m) do not shrink). Embankment has reduced the Deben's tidal area from 2500ha to 974ha resulting in a 60% reduction in tidal prism and an increase in intertidal accretion and new saltmarsh growth (e.g., Loder's Cut Island).

Peter Wain provides some historical background in his article 'The Deben River Walls'³, <http://www.riverdeben.org/wp-content/uploads/2019/11/The-Deben-59-Autumn-2019.pdf>. New areas of saltmarsh are appearing in several parts of the estuary along the mud flats. As soon as the mud level is sufficiently high (about 0.3m below saltmarsh level) *Spartina anglica* – a recently hybridized cord grass c1850 - starts to grow, forming a nucleus for new saltmarsh. Erosion takes place along the edge of the saltmarsh mainly due to wave fetch and Shore Crab (*Carcinus maenas*) burrowing (see video [Shore crabs in Suffolk saltmarsh - YouTube](#)). Wave fetch erosion is greatest from the direction of the prevailing South Westerly winds.

The use of local dredged mud has been successful in producing new saltmarsh, but only when the level of the deposit has reached that of the existing saltmarsh plus about 150mm (1.9m AOD). One example of this has been the silt pumped from the pontoon area at Melton Boatyard on to the semi-enclosed marsh area on the Sutton side of the river. Another example has been the use of a crane grab bucket to dredge solid mud and deposit it in places to regenerate saltmarsh. This has been successful at the north end of Loder's Cut Island⁴, <https://www.youtube.com/watch?v=hBPnSqrG7Fo>.

There is very little information available describing the physical changes occurring in saltmarshes. One such is a Defra R&D Report (FD1922/TR), '<[Managed realignment at Tollesbury - Defra, UK](#)>⁵'. This report describes the settlement of sediment on the saltmarsh close to the river Blackwater in Essex.

A number of projects intended to restore or retain the saltmarsh on the river Deben have been carried out since 2009¹, '<[Saltmarsh Restoration](#)>', using natural materials (faggots, brushwood, polder fence work). So far these do not appear to have been successful.

This paper describes a pilot study carried out by the River Deben Association Saltmarsh Research Group. Although the paper received a grant from the AONB, Suffolk Coast & Heaths, the contents are the views of the authors. It has been inspired by the concern of Robert Simper, Richard Steward and Dr Robert Hughes¹², expressed in a video⁸ of 2011. There are three areas where survey work has taken place: The first, at Loder’s Cut island, starting in 2014. The second, to the north of Waldringfield, starting in 2016. The third, to the south of Waldringfield, starting in 2019. The purpose of the work:

- At Loder’s Cut Island situated near Kyson’s Point in Woodbridge has been to monitor the saltmarsh over a period of several years to assess changes to its vertical and horizontal dimensions and the vegetation growing there.
- At the sites to the north and south of Waldringfield to measure the change in level of the saltmarsh and of the mud in drainage channels, the erosion rate at the edges of the saltmarsh, the effect of creating an impermeable sill in two of the channels, and the effect of placing crab exclusion netting along the edge of the saltmarsh.

The data for the survey work for this project (including Tam Grundy’s mooring surveys) has been recorded in spreadsheets (available on request).

4. Historic background

The Deben Estuary has a tidal area of 974 hectares (obtained from Google Earth) of which 235 hectares are classed as saltmarsh in 2020. Figure 1 shows the results of surveys from CGP⁷, Boyes & Thomson¹⁰, Geomatics⁹, RDA SRG. The current trend of erosion is at a rate of 0.6 ha/year.

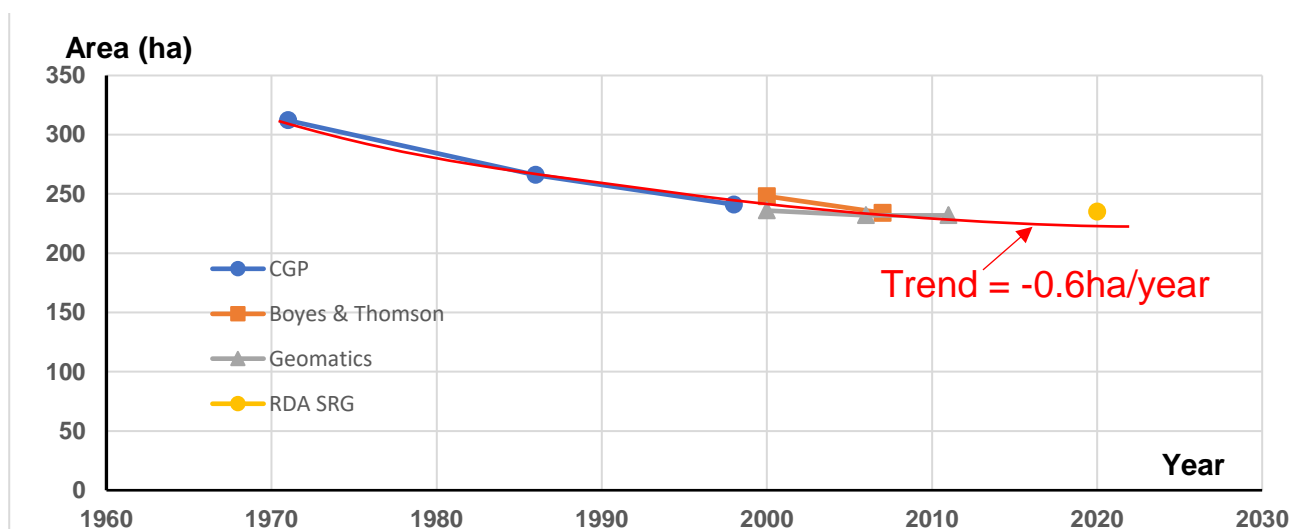

Figure 1: Saltmarsh erosion

The length of saltmarsh along the river edge (Google Earth), including each side, is about 38,000m so the mean erosion rate for each side of the river is $0.6 \times 10,000 \times 1,000 / 38,000 = 158\text{mm/year}$. About 75% is vegetated saltmarsh (180 hectares) and 25% drainage channels and lagoons. The surface level of the mature saltmarsh (> 300 years) is the same throughout the length of the estuary (Felixstowe Ferry to Bromswell/Wilford Bridge), currently about 1.75m ($\pm 100\text{mm}$) above Ordnance Datum.

Mature saltmarsh is being continuously eroded by a combination of wave fetch, tidal flow and Shore Crab (*Carcinus maenus*) burrowing, however, in places along the shore where the saltmarsh cliff is less than 100mm, new patches of *Spartina* are growing, increasing accretion by slowing tidal currents and reducing wave action. Long fetches allow the wind to build up large waves that attack the edges of the saltmarsh (very noticeable on the Blackwater with a 3Km SW wind fetch). Waves from the wake of large motor vessels also cause erosion of the saltmarsh. Saltmarsh protects the toe of the river walls by absorbing wave energy.

Apart from maintenance and the introduction of three sills, no major embankment changes have taken place in the last 50 years. Despite the continual erosion of the saltmarsh, sediment is being deposited from the sea into the Deben estuary. The saltmarshes have been rising to keep pace with mean highwater springs (MHWS) sea level rise (SLR), currently about 3.5mm/yr (see Annex C). Thus about $3.5 \times 180 \times 10 = 6,300\text{m}^3$ (10,709 tonnes) is being deposited on the saltmarsh each year. The riverbed sedimentation rate could be as high as 10mm/yr, similar to that of the Blyth where sedimentation on the breached marshes is outpacing SLR by about 3:1 (Blyth Estuary Sedimentation Report 2009⁶ – Average sedimentation rate +9.7mm/yr). Tam Grundy has measured an average sedimentation rate of 11mm/yr around the moorings between Woodbridge and Methersgate. If this is occurring throughout the estuary the Tidal Prism would be reducing at 0.3%/yr.

Further reading

Allen J R L and Pye K (1992) *Saltmarshes: Morphodynamics, conservation and engineering significance*. Cambridge University Press, Cambridge.

Nottage A and Robertson P *The saltmarsh creation handbook: a project manager's guide to the creation of saltmarsh intertidal mudflat*. 2005 Royal Society for the Protection of Birds

Environment Agency - Anglian Region: *Suffolk Estuarine Strategies River Deben: Strategy Report Volume 1 Main Report* Nov 1999.

5. Description

5.1 Loder's Cut Island: Loder's Cut Island lies just south of Woodbridge (see Figure 2a). It is a relatively young saltmarsh, developed from mud flats over the last 120 years. The cut was created in the mid-1800s to reduce the difficulties that working barges had in reaching Woodbridge. Part of a chart from a hydrographic survey, carried out in 1843 before the cut was made, is shown here.

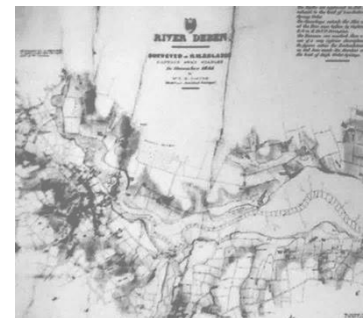

The cut is marked with 'withies' and is in continuous use by local and visiting craft, as an alternative to the main river channel. Monitoring of the saltmarsh started in September 2014 and measurements have been taken at six-month intervals. Figure 2b shows the layout of the twelve measuring posts.



2a)

2b)

Figure 2: Location of Loder's Cut Island and position of the twelve posts

The following information has been recorded at each pole:

- Height of pole above the saltmarsh.
- Orthogonal distances A, B, C and D from the pole to the edge of the saltmarsh (where relevant).

Table 1 gives the coordinates of each pole and the template for recording the data is given below.

Table 1: GPS Coordinates of Survey Poles

Pole Number	Survey Pole GPS Coordinates	
	Northing	Easting
1	52° 04.748'	001° 18.922'
2	52° 04.767'	001° 18.929'
3	52° 04.781'	001° 18.937'
4	52° 04.791'	001° 18.951'
5	52° 04.809'	001° 18.960'
6	52° 04.803'	001° 18.983'
7	52° 04.784'	001° 19.004'
8	52° 04.778'	001° 18.988'
9	52° 04.742'	001° 18.999'
10	52° 04.744'	001° 18.982'
11	52° 04.741'	001° 18.961'

Template for recording data

Date:	Time:	Pole No.
High Water: Time:	Height:	GPS Point at
		N
		E

Height (mm)	A	B	C	D

Weather conditions:

Wind speed and direction:

Approx height of tide at start of recording (indicate ideal time for visiting site):

Notable recent weather events:

Notes:

12	52° 04.742'	001° 18.947'
----	-------------	--------------

Apart from the survey work, an experiment has been carried out to place solid dredgings to regenerate saltmarsh. 750m³ of mud was dredged from the mud bank at Ferry Dock and the Deben Yacht Club in Woodbridge in 2015 (and further dredgings in 2017). This was transported by barge and placed at the north end of Loder's Cut Island. This has remained in place and allowed four different species of maritime plants to grow within a year. In 2016 the upper margins of this deposited strip had a thick cover of *Salicornia* spp. as well as occasional Sea Aster (6-7 plants) and one *Spartina* plant. There were also signs of bird feeding on the un-vegetated lower margins on the channel/cut side. Figure 3 shows the area in plan and photographs of the new saltmarsh looking from the east and north-west.

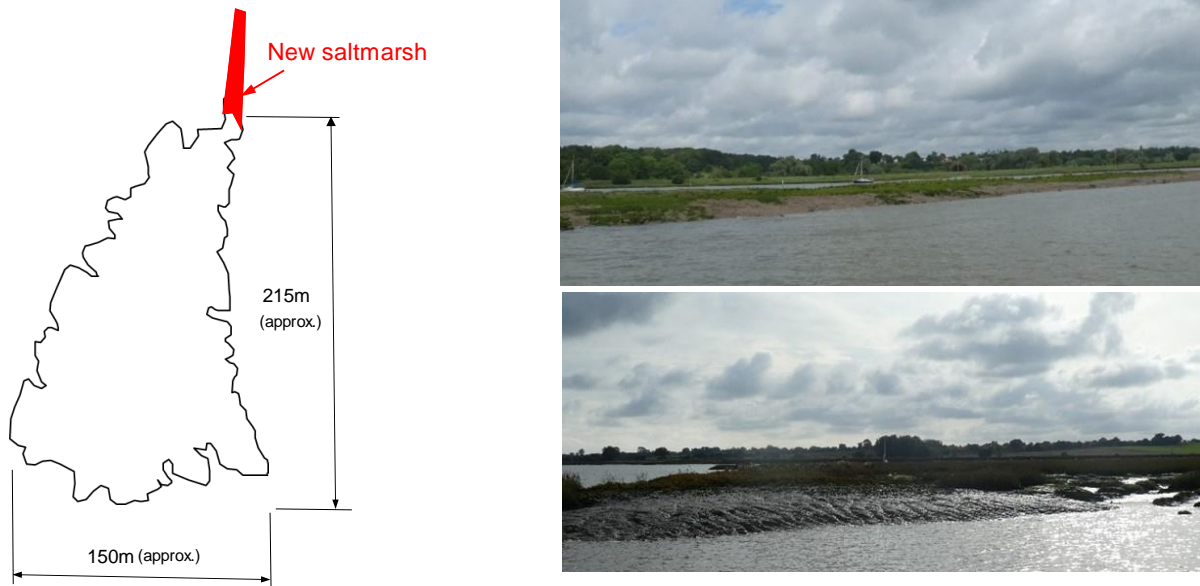
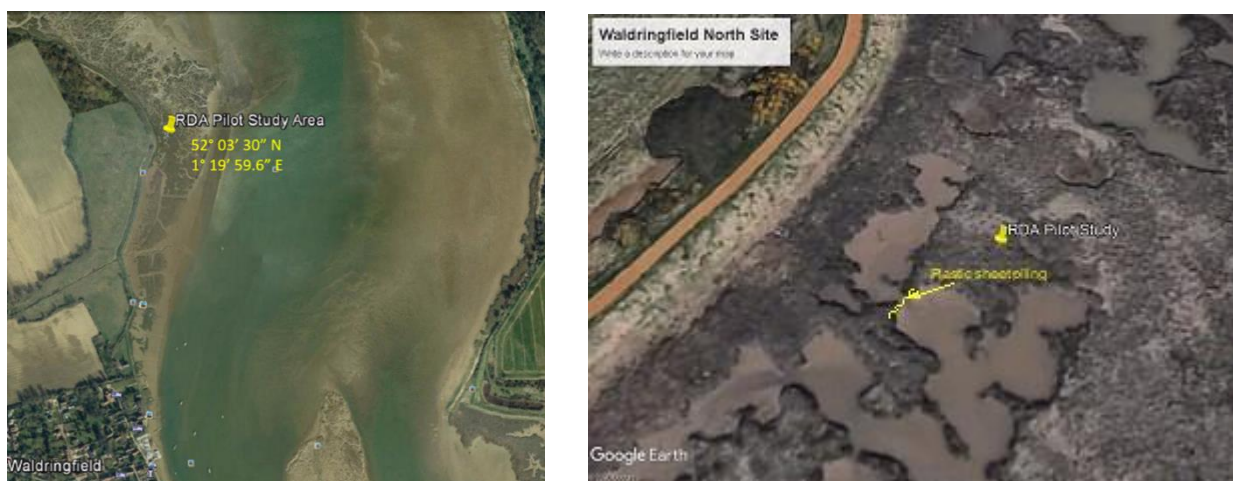

Figure 3: Plan showing new saltmarsh with photos from east (above) and north-west (below)

5.2 Saltmarsh Pilot Study at Waldringfield: This site is situated half a mile north of Waldringfield as shown in Figure 4.



a) General area

b) Local area

Figure 4: Location of Pilot Study Area north of Waldringfield

The project received Environment Agency (EA) ‘Flood Defence Consent’ in April 2016 (FDC-ENS-2016-1126) and a Marine Management Organisation (MMO) licence in May 2016 within the Waldringfield Flood Defence Group’s licence (L/2016/001455/1). Monitoring work started in September 2016. In May 2018 the project received support from the AONB, Suffolk Coast & Heaths, ‘Sustainable Development Fund 2018-19’ (SCH SDF 02).

The purpose of the pilot study has been to measure changes in saltmarsh level, the erosion at the edges of the saltmarsh and investigate the role that shore crabs and ragworms may have in these changes. Crab exclusion cages and ragworm exclusion plates have been used to assess the effect of crab and ragworm bioturbation on drainage channel sedimentation. In addition, a method of increasing sedimentation in drainage channels using a sill has been investigated. Figure 5 shows the sheet piling (Linlar Std Pile Grey) used to create a sill across a drainage channel. The length of the sheet piles is 1.5m and they have been extended horizontally 0.5m into the saltmarsh to prevent leakage around the ends. The sill is set at 200mm below the level of the saltmarsh.



a) Installing the sheet piling

b) Sill created by sheet piling

Figure 5: Placing of plastic sheet piling across a drainage channel

The following measurements have been taken:

- a) **Change in saltmarsh level.** Three 2m x 50mm diameter plastic tubes were pushed 1m into the surface of the saltmarsh and measurements taken from the top of the tube to the marsh surface.
- b) **Change in drainage channel mud level.** To assess the effect of ragworm and shore crab bioturbation on mud levels, four 0.5m patches were set up for measurement (see Figure 6). Each patch had a pair of 2m aluminium rods set 400mm apart, horizontally and vertically aligned and pushed 1.5m into the mud. Laser distance measurements were taken from the top surface of a removable channel placed on top of the rods. Annex B describes the measuring equipment in detail. A temporary walking board was placed on the surface of the mud to provide access.

The four patches consisted of:

- i) A control area with an open natural mud surface
- ii) A crab exclusion cage. The original galvanised mesh cages corroded after four years and are being replaced with plastic coated galvanised mesh cages.

- iii) A 300 x 300mm perspex plate to exclude ragworms. This is laid on the surface and pegged in opposite corners with two 0.5m aluminium rods.
- iv) A combined cage and plate to exclude both ragworms and crabs

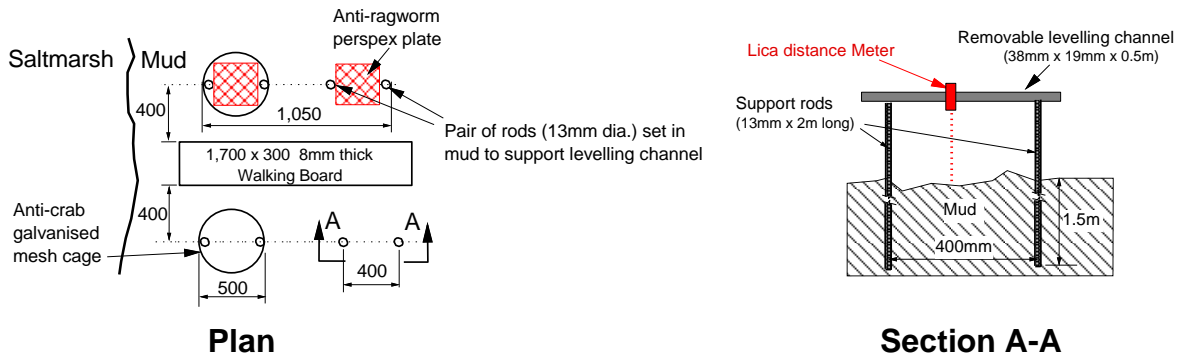
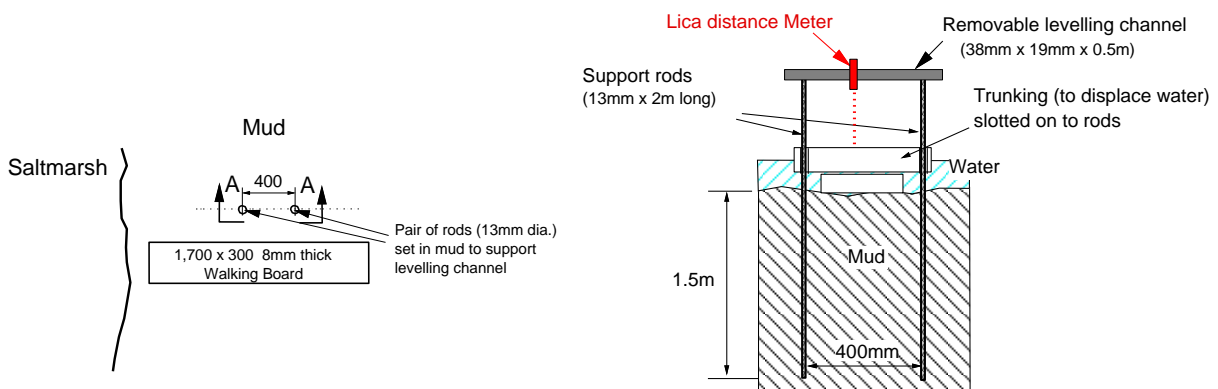

Figure 6a: Arrangement of equipment for measuring change of level of mud



Figure 6b: Arrangement of equipment for measuring change of level of mud

- i) **Erosion of the saltmarsh edges both at the river's edge and within the heart of the saltmarsh.** This was measured using bamboo sticks, pushed into the edge of the saltmarsh.
- j) **Change in sill lagoon mud level.** A similar arrangement to that for the control area in b) above was setup (see Figure 7). In addition, a 220mm plastic trunking spacer was used to allow measurement to be taken above the water line.



Plan

Section A-A

Figure 7: Measuring the mud level in the sill lagoon.

In 2018 the work was extended to include a second plastic sheet pile wall closer to the river channel (see Figure 8), placing more sticks along the edge of the saltmarsh, and the introduction of crab exclusion netting (see Figure 9 &10). 19mm Diamond Mesh Anti-bird netting.



Figure 8 Location of the second plastic sheet pile wall

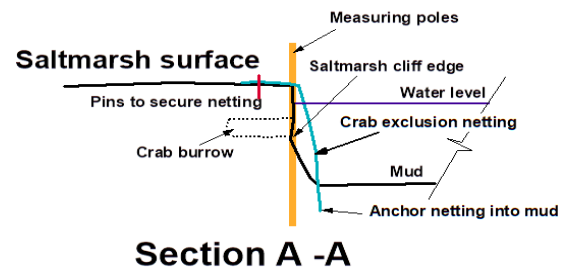
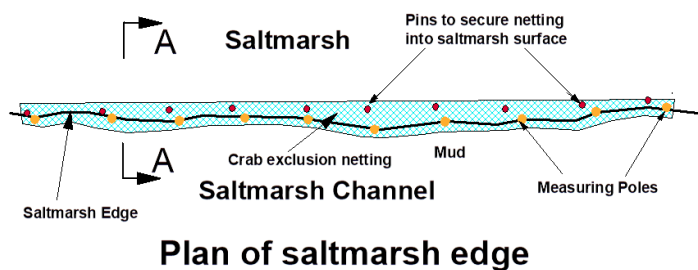

Figure 9: Crab exclusion netting



Figure 10: Placing of crab exclusion netting

5.3 Extension to saltmarsh Pilot Study at Waldringfield: An application to extend the survey to a site south of Waldringfield (see Figure 11) was made to the EA and MMO in November 2018.



Figure 11: Location of the extension site

The EA confirmed that this extension to the Pilot Study did not require a Flood Risk Activity Permit (previously known as Flood Defence consent). In December 2018 the MMO confirmed that the extension would be permitted through an exemption (EXE/2018/00264). The owner of the saltmarsh to the south (Miss Rosa Waller) gave her permission.

6. Results and Discussion

Measurements were recorded in three spreadsheets:

- ‘Loder’s Cut Island measurements’
- ‘Pilot study north of Waldringfield results’
- ‘Pilot study south of Waldringfield results’

6.1 Loder’s Cut Island: At the start of the project a survey of vegetation within 1m² perimeter of each post was carried out by Carol Reid. This is reproduced in Annex A.

A spreadsheet ‘Loder’s Cut Measurements’ records the data and the analysis of it.

Measurements have been taken in the Spring and Autumn of each year since 2014. At the time

of writing this report 14 No. surveys have taken place (the most recent taken in the Autumn of 2020).

6.1.1 Change in level of the saltmarsh: Figure 12 shows the mean of these changes and the trend with time. The trend shows the saltmarsh rising at 6mm/year. This saltmarsh is relatively young (say 150 years old) and its level is low compared with the mature saltmarsh within the estuary, so it should be expected to have a higher rate of increase than sea level rise and the more mature saltmarsh elsewhere in the estuary (about 4mm/year).

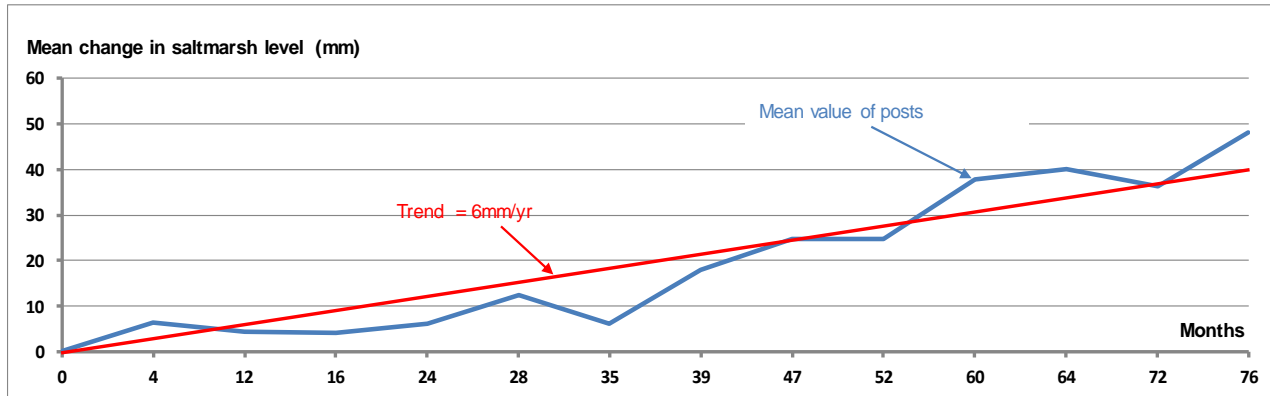

Figure 12: Mean changes of saltmarsh level with time and the trend

6.1.2 Change in area of the saltmarsh: For the first eight surveys measurements were taken from each post to the four orthogonal edges of the saltmarsh. The points on the saltmarsh to which measurements were taken relied on judgement. This led to inconsistent results. In May 2018 bamboo sticks were placed at the edge of the saltmarsh at the four orthogonal points. The results, since these were installed, have also been inconsistent and several of the sticks have disappeared. Apart from the north corner of the island, where solid dredgings have been deposited and the saltmarsh has been regenerated, there has been little change in the net area of saltmarsh.

6.2 Pilot study to the north of Waldringfield: Six surveys have taken place since 2016 (the most recent taken in the Autumn of 2020). Figures 13(a-c) show the layout of the measuring equipment (posts, sticks, mud measuring rods, crab cages and ragworm plates).

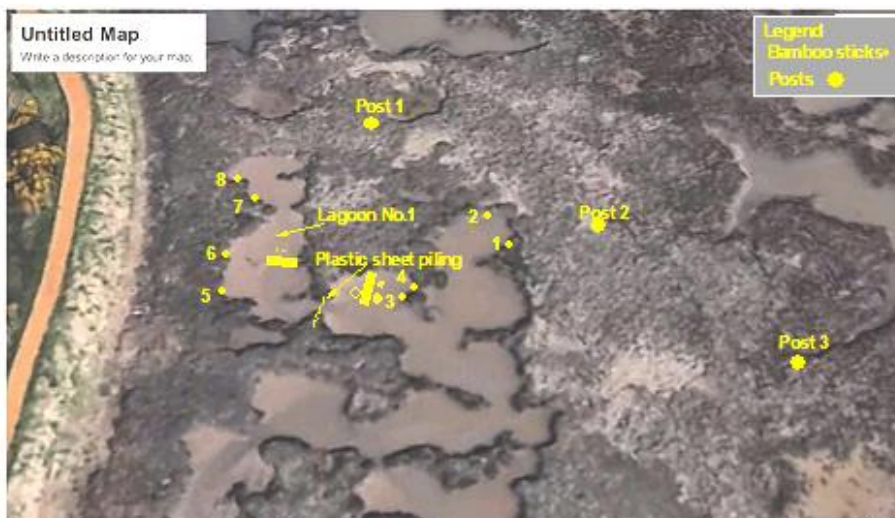

Figure 13a: Layout of measuring equipment north of Waldringfield

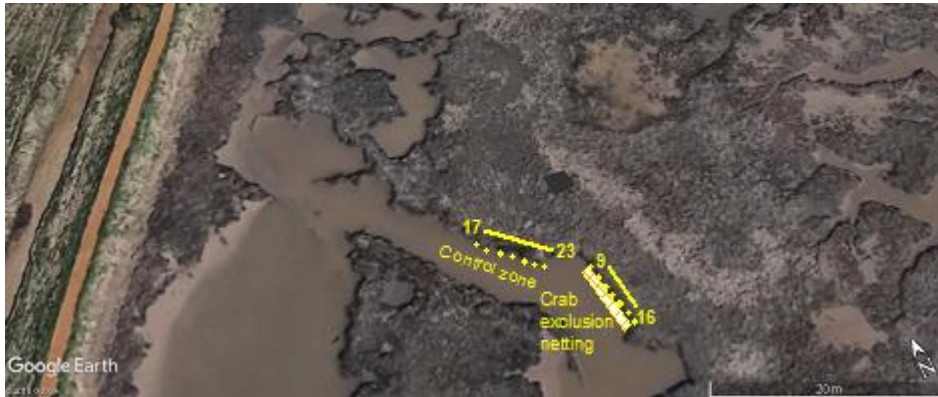

Figure 13b: Layout of measuring equipment north of Waldringfield



Figure 13c: Layout of measuring equipment north of Waldringfield

6.2.1 Change in level of saltmarsh: The original level of the posts was set to 1000mm above the saltmarsh level. The first reading of 1009mm indicates that the saltmarsh has shrunk or that the posts have risen slightly from their original position. To compensate this, the datum has been taken as 1005mm. The mean increase in saltmarsh level at the three posts after three and a half years is 3mm/year. This is 0.5mm less than the sea level rise (currently 3.5mm/year, including the effects of the settlement of the land and tidal range). Over a long period of time (say ten years) this measured value is expected to become close to the value of mean sea level rise (see results for Loder's Cut Island, 6.1.1).

6.2.2 Change of mud level in the drainage channels and lagoons: The mean increase in mud level after four years has been 1.9mm/year. This is 1.6mm/year less than the sea level rise (3.5mm/year). The reasons for the change in level of the mud are more complicated than those for the saltmarsh level and will include effects of ragworm burrowing, shore crab and bird feeding and intense rainfall on the last of the ebb. The trend shows an increasing difference in the level of mud and saltmarsh.

6.2.3 Change of mud level with ragworm exclusion plate: The mean increase in mud level after four years has been 2.2mm/year. This is 1.3mm/year less than sea level rise (3.5mm/year).

6.2.4 Change of mud level with a shore crab exclusion cage: The mean increase in mud level after 30 months has been 5.4mm/year. This is 1.9mm/year more than sea level rise (3.5mm/year). This is the highest of the four test patches and is a similar rate to that of the surrounding saltmarsh (5mm/yr). The three remaining test patches ('Control', 'Plate' and 'Cage & Plate') had less than half the sedimentation rate (2mm/yr). This appears to indicate that, in the absence of crabs, fish and birds, ragworms are able to stabilise the mud surface with their mucus nets¹¹ making the surface resilient to erosion from waves and rain on the ebb. The worms may also be eating small soft bodied animals which would normally disrupt the mud surface making it prone to erosion.

6.2.5 Change of mud level with plate and cage: The mean increase in mud level after 30 months has been 2mm/year. This is 1.5mm/year less than sea level rise.

6.2.6 Mean rate of erosion of the edges of the saltmarsh: The mean erosion rate for each area measured is shown in Tables 2 and 3. Table 2 show the mean results for a period of 3½ year. In 2018 the Pilot Study was extended to include three sticks along the river edge. In addition, eight bamboo sticks were placed along the edge of the saltmarsh to measure the effect of the crab exclusion netting (see Figures 13b and 13c). Seven further sticks were placed along the saltmarsh edge in a control area close by. Only one set of results have been recorded so far in Table 3 and the results are unlikely to show the trend correctly.

Table 2: Mean erosion rate of saltmarsh edge over 3½ years

	Channel edge outside lagoon No.1	Channel edge inside lagoon No.1	Overall
Mean erosion (mm)	30	90	70
Mean erosion rate (mm/year)	9	26	20

Table 3: Mean erosion rate of saltmarsh edge for the Extension Study over 2¼ years

	River edge	Channel edge outside 2 nd lagoon (A)	Channel edge inside 2 nd lagoon (B)	Crab Exclusion Netting	Edge without netting (C)	A, B & C
Mean erosion (mm)	183	8	2.7	40	47	29
Mean erosion rate (mm/year)	85	4	2	19	22	22

Measurements of erosion of the saltmarsh at the river edge has only been taken at three sticks placed at one locality and is insufficient to give any overall indication.

However, measurements of erosion taking place in the heart of the saltmarsh have been used to give an overall indication. Annex D describes how this information can be used to link with the overall behaviour. From the analysis of four areas the mean overall length of saltmarsh edge within the heart of the saltmarsh along the channels and around the lagoons has been calculated to

be 394km. Using the mean value of 21mm/year the rate of overall erosion is $0.021 \times 394/10 = 0.83\text{ha/year}$. This compares with the rate along the river edge of 0.6ha/year (See section 4).

It is too early to learn the effect that crab exclusion netting is having on the erosion of the edge of the saltmarsh. This will become clear with time.

6.2.7 Mud accretion within trapped area of lagoon No 1: The level of the sill, formed with plastic sheet piling, was set 200mm below the saltmarsh level. It has created a semi-sealed lagoon (See Figure 13a), the area of which is 50m^2 . The investigation relies on preventing the ebb falling lower than 200mm below saltmarsh level. Most of the suspended sediment contained in the flood tide flowing over the sill is deposited over 8 to 10 hours on each tidal cycle. Furthermore, the sill prevents the loss on the ebb of bioturbated sediments from crabs and soft bodied animals. The level of the mud has risen over 60mm in two and half years (3m^3) at a mean rate of 15mm/year (11.5mm/year more than sea level rise). Figure 14 shows the change in mud level over this period.

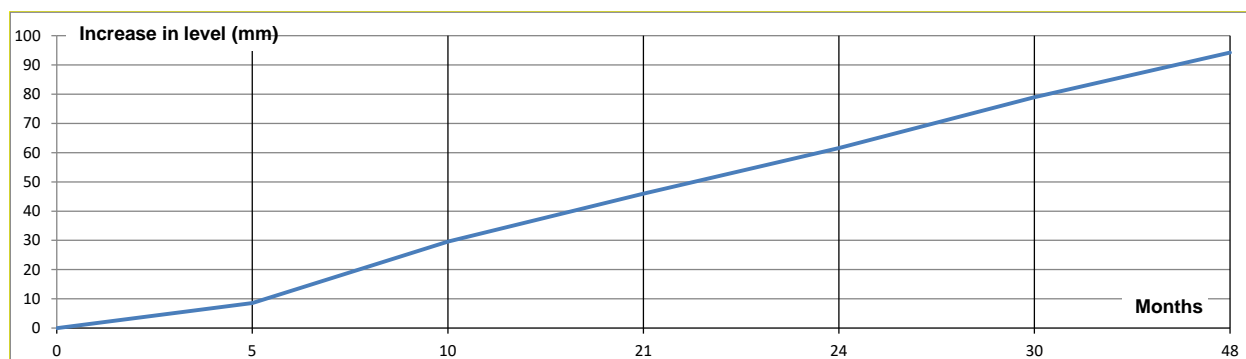

Figure 14: Change of mean mud level in lagoon No.1

6.2.8 Mud accretion within trapped area of lagoon No 2: Measuring rods were placed in lagoon No.2 in September 2020, so it will be some time before accretion rates are recorded.

6.3 Pilot study to the south of Waldringfield: The Pilot Study was extended to include a site south of Waldringfield in April 2019. One survey has taken place since 2019, in the Autumn of 2020. Further bamboo sticks were added at this time (Nos. 7-13). Figure 15 shows the layout of the measuring equipment (posts, sticks, mud measuring rods, crab cages and ragworm plates).

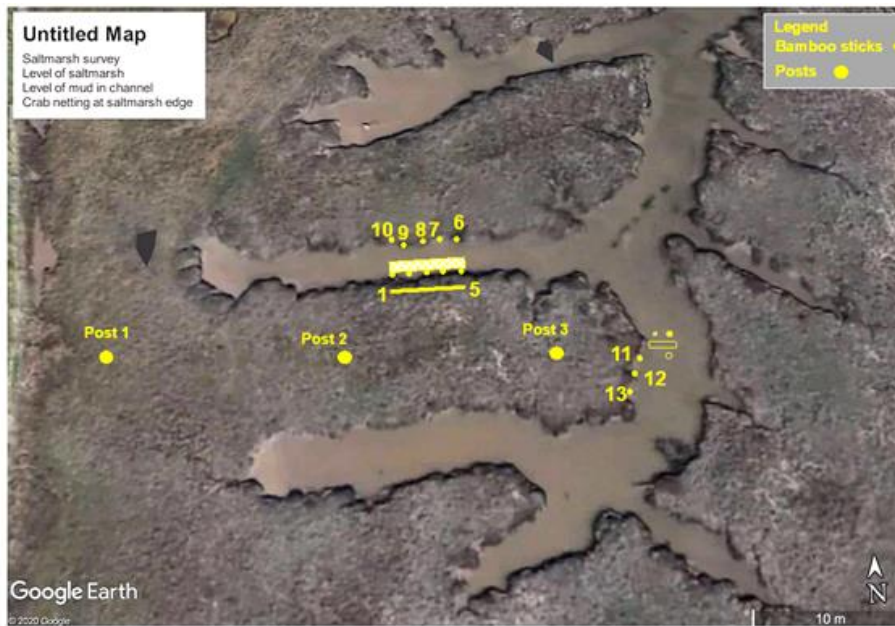

Figure 15: Layout of measuring equipment south of Waldringfield

6.3.1 Change in level of saltmarsh and mud: Only one set of measurements have been made after seventeen months. More readings are required to make any useful judgement.

6.3.2 Rate of erosion of the edges of the saltmarsh: There is only one measurement of the saltmarsh edge without crab exclusion netting, bamboo stick No. 6. This shows an erosion rate of 150mm (106mm/year). The mean erosion rate for the length with crab exclusion netting is 15mm/year. This would imply that the crabs are the main cause of erosion of the saltmarsh edge within the saltmarsh area. Future readings will confirm or otherwise this trend.

7. Conclusions

7.1 Change of level of saltmarsh: Sediment is being deposited on all three sites. The rate of sea level rise (SLR) is about 3.5mm/year (see Annex C).

The rate of sedimentation is greatest for the least mature saltmarsh at Loder's Cut Island (150 years). The mean rate is 6mm/year over a period of 6½ years, 2½ mm greater than SLR.

The rate of sedimentation for the saltmarsh to the North of Waldringfield has been 3mm/year over a period of 3½ years of measurements.

The rate of sedimentation for the saltmarsh to the South of Waldringfield has been 2mm/year over a period of 1 year of measurements. This value is likely to increase over a longer period.

It can be reasonably concluded that the saltmarsh is rising at a similar rate to MHS SLR and that the saltmarsh level is rising at a constant rate throughout the tidal length (same level at Felixstowe Ferry as at Woodbridge).

7.2 Change in area of saltmarsh: In addition to the erosion to the saltmarsh taking place along the river edges of 0.6ha/year (see Section 3) measurements show that 0.83ha/year erosion is taking place within the heart of the saltmarsh (increasing the size of channels and lagoons). In

contrast to this erosion, it has been shown that saltmarsh can be regenerated with the use of solid dredgings (see section 5.1).

7.3 Change of mud level in saltmarsh drainage channels and lagoons: The preliminary results of the sedimentation patch experiment show a loss of elevation relative to the surrounding saltmarsh of about 1.5mm/yr, with the exception of the cage only patch (excluding shore crabs, fish and birds) which shows a gain of 1.9mm/yr. The cage only results suggest that, protected from shore crabs, rag worms are able to retain all the available sediment deposited on the mud surface from the tidal flow. It is likely that undisturbed from predation and bioturbation from crabs, birds and fish, rag worms, whose known feeding method is surrounding the entrance to their burrows with mucus nets, is preventing surface sediment loss. Further research is required here.

7.4 Mud accretion within trapped area (sill) of the lagoons: A steady rate of natural accretion of over 15mm/year has occurred in lagoon No. 1. This demonstrates that it is possible to help restore saltmarsh. However, the rate of accretion will slow down as the level of the sediment rises and it will never reach the level of the existing saltmarsh to allow new saltmarsh to start growing. It will need the addition of dredgings to reach this.

8. References

1. Whittle R. & Simper R. Saltmarsh restoration: Oct 2017: RDA Web site
2. Steward R. & Whittle R. Saltmarsh and River Wall Protection: Feb 2019
3. Wain P. The Deben River Walls: The Deben No. 59 Autumn 2019
4. Use of Dredgings: <https://www.omreg.net/query-database/224-loders-cut-island/>
5. Managed realignment at Tollesbury - Defra, UK: 2008
6. Blyth Estuary Sedimentation Report: 2009
7. Saltmarsh changes within the Suffolk estuaries between 1971, 1986 and 1998: Coastal Geomorphology Partnership (CGP); Department of Marine Sciences and Coastal Management; University of Newcastle: December 2000
8. [YouTube - Crabs And Ragworm Eroding Salt Marsh In East Anglia - JeremyShiers.com BlogJeremyShiers.com Blog](#)
9. Geomatics. Deben Estuary Saltmarsh Re-mapping & Change analysis 2000 – 2011: Apr 2013
10. Boyes S. & Thomson S. Suffolk Estuarine SSSIs – Assessment of Changes in Extent of Saltmarsh Over the Period 1999/2000 to 2006/2007: Jan 2018
11. Levinton, J. Bioturbators as ecosystem engineers: 1995.
12. Hughes R G. Saltmarshes – Features, Importance and Conservation. *The Deben* 46 Spring, 2013, Page 11. [Layout 1 \(riverdeben.org\)](#)

Annex A: Loder's Cut Island survey of vegetation (21 June 2014)

Method

The survey was begun 50 minutes before high tide in order to facilitate access. A 1m² quadrat was placed around each post and the percentage cover of vegetation was assessed. The extent of bare mud and water bodies was also recorded (tide cover was not included as a water body). The tide covered some of the quadrats during the survey which made it difficult to estimate percentage cover of species and features. The vegetation around the base of each post lying within the quadrat was photographed recording the direction the camera was pointing and the time the photo was taken. Photographs were also taken showing the post number and adjacent marsh. Post 10 could not be accessed for quadrat survey. The predicted height of the tide and weather conditions was also noted. This information is summarised in an excel spread sheet (Table A1). The location of the posts is indicated on a Google earth aerial image, plotted from co-ordinates supplied by the River Deben Association (Figure A1). The table and photos are included as separate file attachments.

Results and comments

Only 4 plant species were found in the quadrats: *Spartina anglica* (common cord-grass), *Salicornia* sp (glasswort or samphire), *Aster tripolium* (sea aster), and algae. With the exception of Quadrat 9, *Spartina anglica* was the dominant species in the quadrats, with cover values ranging from 35 to 100 percent and mostly in excess of 70%. In quadrat 9, *Aster tripolium* was the most widespread species. The vegetation around Post 10 was predominantly *Spartina anglica*. Bare mud averaged 20% over the quadrat area. In several places across the island filamentous algae had spread over eroded bare mud devoid of saltmarsh growth. Most of the island was under water at high tide (Harwich Harbour tide table predicted HW 3.69m). Bar charts showing percentage cover of all the species/features in the quadrats are provided below (Figure 2).

Spartina anglica is frequently found in the estuary as a zone of vegetation growing seaward of other saltmarsh communities. It extends below the growth range of other pioneer species such as *Salicornia* sp, and *Aster tripolium*. With the island at Loder's Cut submerged on the higher neap tides, these conditions are likely to favour the further spread of *Spartina anglica*. A recent National Vegetation Classification survey commissioned by Natural England (Abrehart & Jackson, 2013) described the NVC vegetation type on the island as a mosaic of SM6 – *Spartina anglica* saltmarsh community (45% cover) and SM11 – *Aster tripolium* saltmarsh community (55% cover). It was suggested in the survey report that SM6 saltmarsh is encroaching into the sea aster community across the estuary. The report compared the extent of the *Spartina anglica* community estuary-wide with a NVC survey carried out by Suffolk Wildlife Trust in 1993. It was estimated that there had been a gain of 59.32 hectares of this vegetation type in the last 20 years, representing a 269% increase. During this period the *Aster tripolium* community had undergone losses of 41.36 hectares (76%) across the estuary.

Table A1. Bar charts showing percentage cover of species/features in the quadrats.

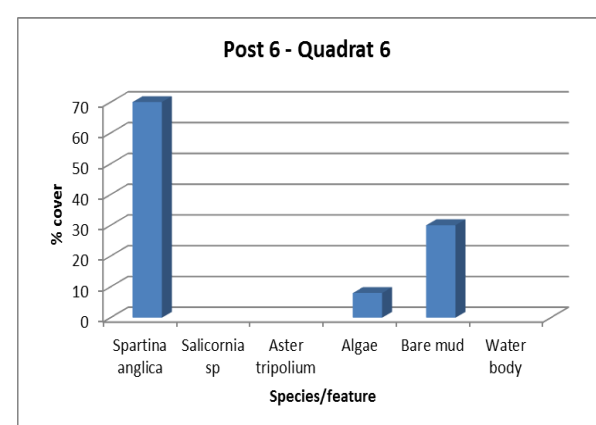
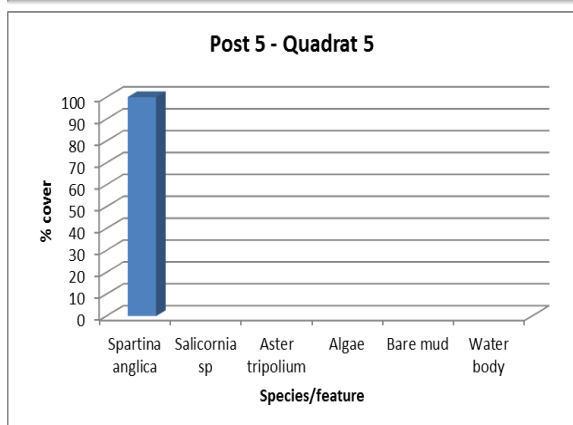
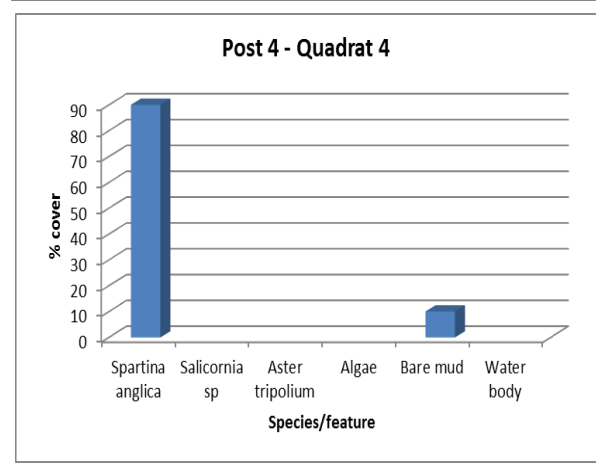
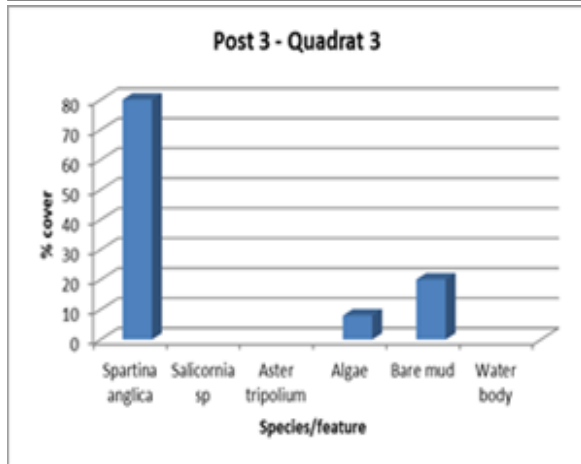
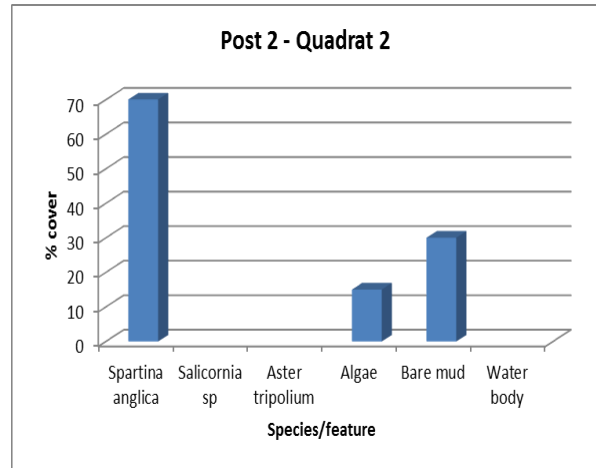
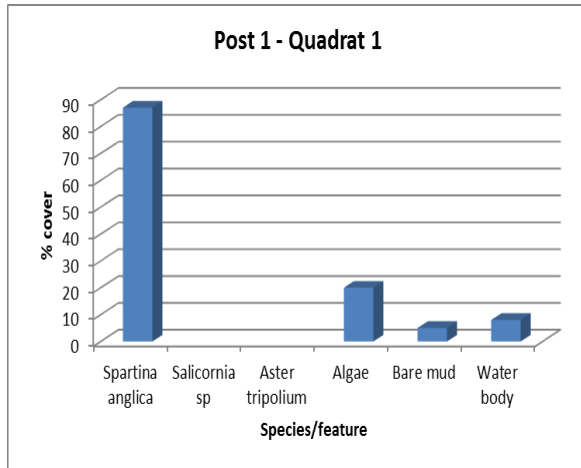

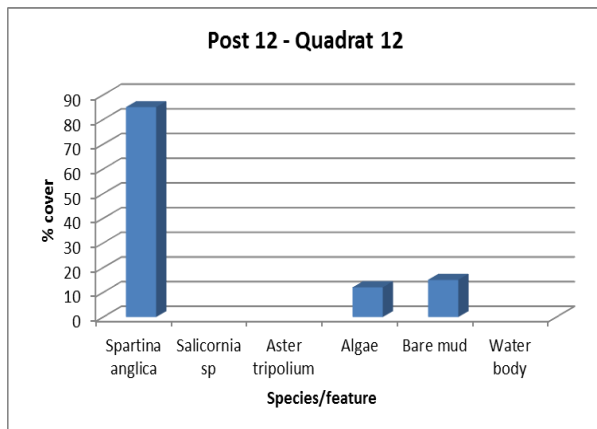
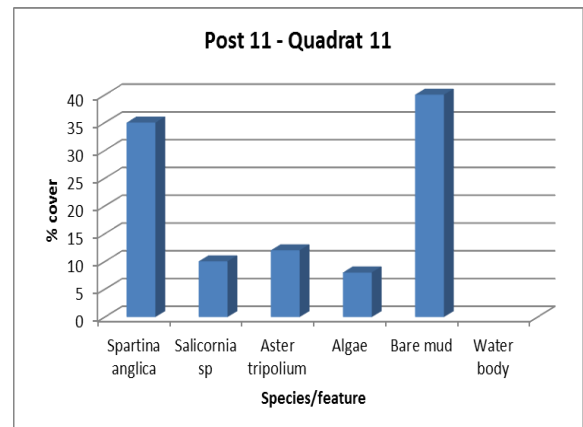
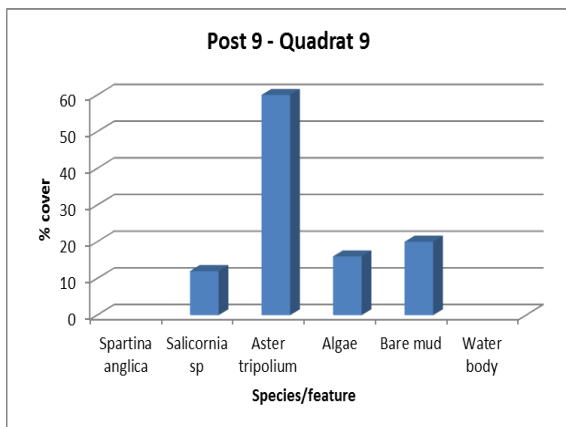
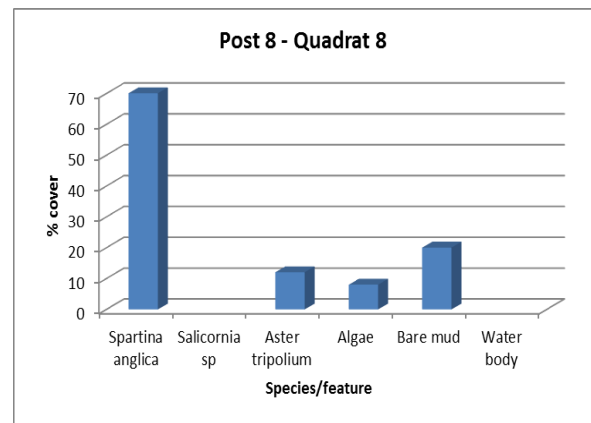
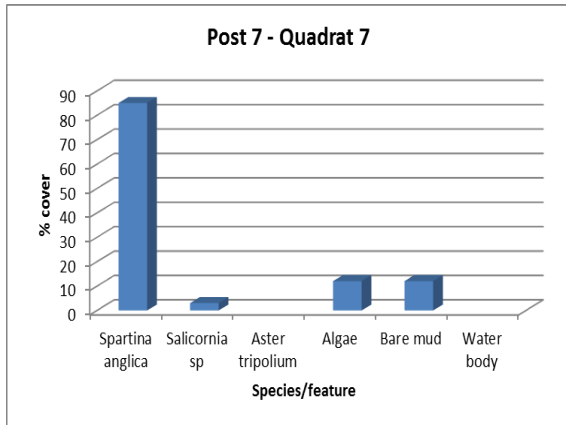

Note: Post 10 was not accessible for survey but viewed from approximately 2 metres away. *Spartina anglica* was the dominant vegetation around the base.



Figure A1. Google earth aerial image showing location of posts on Loder's Cut island (plotted from co-ordinates obtained by River Deben Association).

Reference in text – Abrehart, T. R. & Jackson, R. I. 2013. An NVC Survey of the Deben Estuary SSSI, Suffolk – undertaken for Natural England by Abrehart Ecology. Project reference number: LB13/14-84030-Deben.

Carol Reid – 12 July 2014

Annex B: Equipment for measuring the level of mud

In order to take accurate measurements of the mud it is necessary to gain access without disturbing the mud close to the measuring equipment. To do this a walking board was placed alongside the measuring equipment and close to the saltmarsh edge as shown in Figure 1.

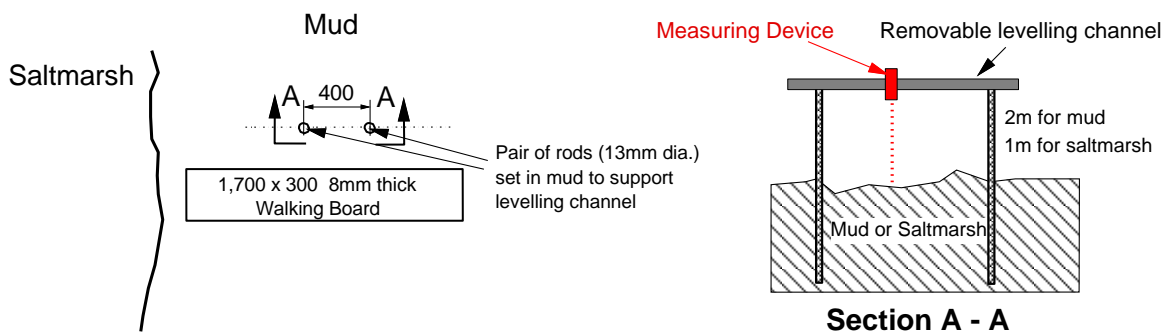
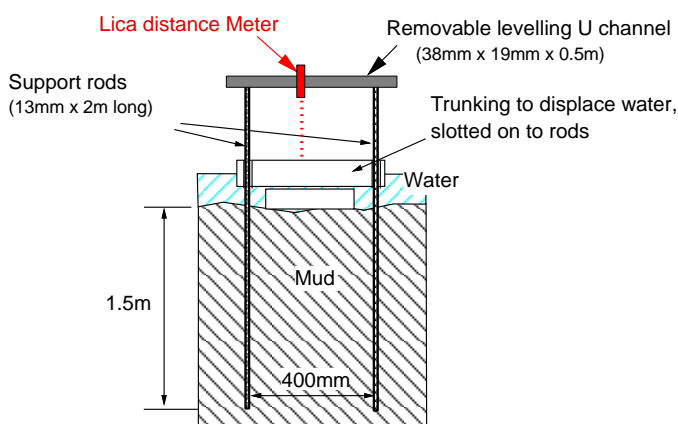

Figure 1: Equipment used for measuring the level of mud

The method for measuring the level of mud incorporates a laser pulse that reflects off the mud surface.

The Leica Disto 510 distance meter sends out a red laser pulse that is reflected off the mud surface back to a detector in the meter. The time difference between the outgoing and incoming pulse is converted to distance to four decimal places and sent together with the meter angle via Bluetooth to a laptop containing the Leica Disto app. This app converts this data to an Excel spreadsheet which is then copied and pasted into a 'final results' spreadsheet.

Where the mud lies below the water level the measurement gets distorted and a 220mm trunking spacer is used to allow measurement to be taken above the water line (see Figure B2).



2a) Cross section



1b) Levelling channel and trunking spacer

Figure 2: Measuring the level of mud under water

Aluminium Tubes ½" x 1.6mm x 2m (10 off /site)
¾" x 1½" x ⅛" x 1m Ali Channel (2 off)



Need a picture measuring the mud and using the trunking when there is a water layer

Annex C: Sea Level Rise

MHWS SLR is the critical relative sea level rise for determining the surge height specification for East Coast sea defences and is the height to which the saltmarshes accrete with a flat but irregular surface of +/- 100mm. MHWS SLR comprises three components

- Mean sea level rise (MSL) 1.4mm/yr (NOC). The UK (Absolute) MSL has been determined by Prof. Philip Woodworth, the National Oceanographic Centre (NOC), Liverpool to be 1.4mm/yr derived from 100 years of isostatic corrected data from tide gauges around the UK. To date, no discernible long-term acceleration has been found in this or in any of the global tide gauges. See links below and Appendix 1. Wismar, Germany (170 years), North Shields, UK (123 years) and Fort Denison, Australia (132 years). Note: These tide gauge records are relative and therefore uncorrected for land movement.

https://tidesandcurrents.noaa.gov/sltrends/sltrends_station.shtml?id=120-022

https://tidesandcurrents.noaa.gov/sltrends/sltrends_station.shtml?id=170-053

https://tidesandcurrents.noaa.gov/sltrends/sltrends_station.shtml?id=680-140

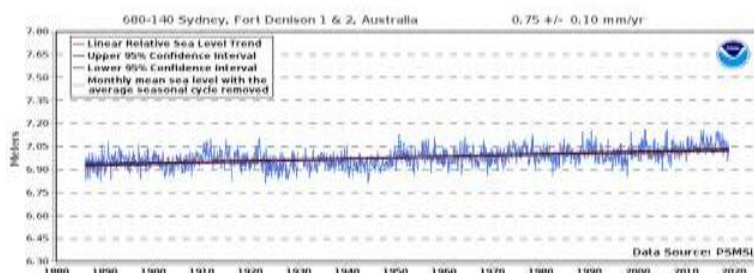
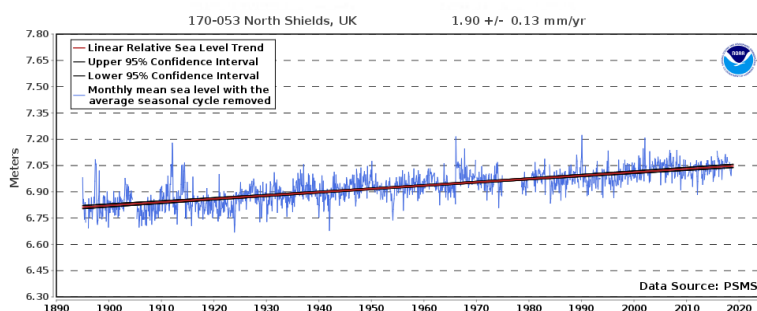
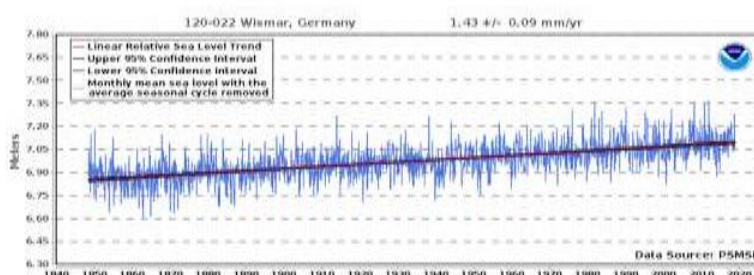

- Isostatic Land Subsidence 1.5mm/yr (Defra FD2319 April 2007 p104) and
- North Sea Tidal Range Increase about 0.6mm/yr due to an increase in North Sea tidal volume from sea level rise and sea floor subsidence.

The total effect is 3.5mm/yr.

Annex D: Internal erosion of saltmarsh

This annex is intended to show how the detail survey information can be used to check the overall behaviour through Google Earth tools. Google Earth can be used to calculate the ratio of the length of the saltmarsh edge to its area. From this it is possible to calculate the erosion that is taking place within the saltmarsh away from the river's edge.

Four areas have been chosen:

Area 1: Saltmarsh to the north of Waldringfield: Area = 0.17ha

Length of saltmarsh edge = 147 + 123 + 173 = 443m

Hence for 180ha Length is $443 \times 180/0.17 = 469,058\text{m}$



Area 2: Saltmarsh opposite The Rocks: Area = 1.19ha

Length of saltmarsh edge = 301 + 131 + 293 + 281 + 338 + 260 + 194 + 121 = 1,919m

Hence for 180ha Length is $1,919 \times 180/1.19 = 290,269\text{m}$



Area 3: Saltmarsh at Hemley: Area = 0.2ha

Length of saltmarsh edge = $130 + 274 + 23 + 23 + 24 = 474\text{m}$

Hence for 180ha Length is $474 \times 180/0.2 = 406,285\text{m}$

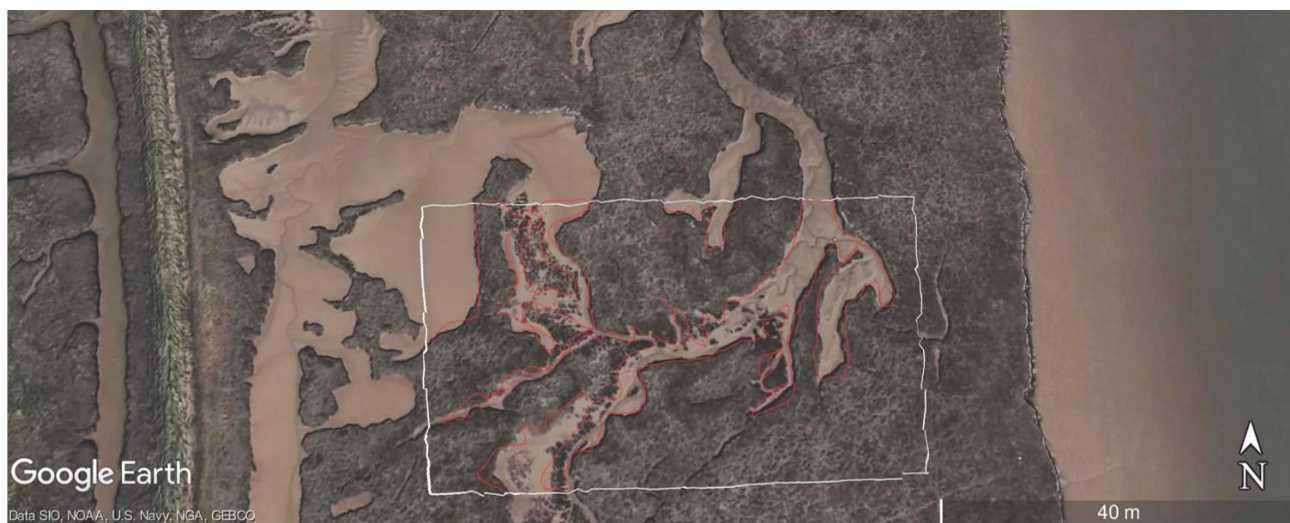

Area 4: Falkenham: Area = 0.13ha

Length of saltmarsh edge = $21 + 186 + 44 + 15 + 6 + 15 + 10 = 297\text{m}$

Hence for 180ha Length is $297 \times 180/0.13 = 411,231\text{m}$



Overall saltmarsh loss

The mean overall length = $(469,058 + 290,269 + 406,285 + 411,231)/4 = 394,211\text{m}$

Taking the erosion rate as 21mm/year (see Section 5.2.6), the loss of saltmarsh = $394,211 \times 0.021/10,000 = 0.83\text{ha/year}$